

单向硅整流桥堆

反向电压 50 ~ 1000 V
正向电流 35 A

Single Phase Silicon Bridge Rectifiers

Reverse Voltage 50 ~ 1000 V
Forward Current 35 A

特征 Features

- 反向漏电流低 Low reverse leakage
- 正向浪涌承受能力强 High forward surge capability
- 高信赖性 High reliability
- 玻璃钝化芯片 Glass passivated chip
- 引线 and 管体皆符合RoHS标准
Lead and body according with RoHS standard
- 型号后缀“-F”标记无卤素产品
Green compound with suffix "-F" on Marking

机械数据 Mechanical Data

- 封装外形:D5 塑封 Case:D5 Molded plastic
- 环氧树脂: UL易燃等级: 94V-0
Epoxy: UL 94V-0 rate flame retardant
- 引脚: 镀锡, 无铅 Lead: Pure tin plated, lead free
- 安装位置: 任意 Mounting Position: Any
- 安装扭矩: 推荐值 0.5牛*米 Mounting torque: Recommend 0.5 N*m

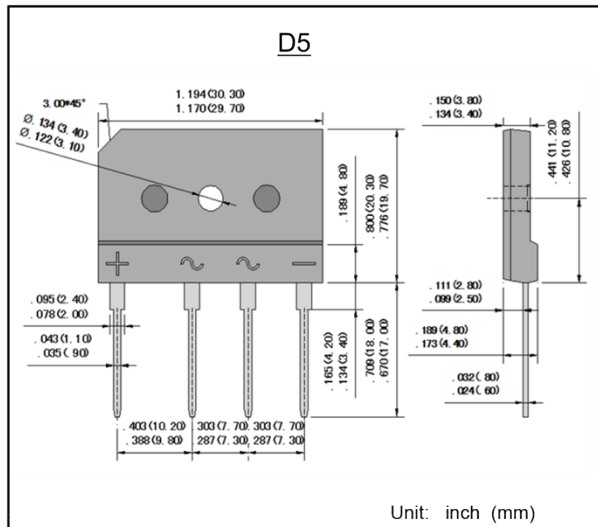

最大值和温度特性 TA = 25°C 除非另有规定。

Maximum Ratings & Thermal Characteristics Ratings at 25°C ambient temperature unless otherwise specified.

参数 Parameter	符号 Symbols	D35S B05	D35S B10	D35S B20	D35S B40	D35S B60	D35S B80	D35S B100	单位 Unit
最大可重复峰值反向电压 Maximum repetitive peak reverse voltage	V_{RRM}	50	100	200	400	600	800	1000	V
最大均方根电压 Maximum RMS voltage	V_{RMS}	35	70	140	280	420	560	700	V
最大直流阻断电压 Maximum DC blocking voltage	V_{DC}	50	100	200	400	600	800	1000	V
最大正向平均整流电流 Maximum average forward rectified current	$I_{F(AV)}$	35							A
正向不重复浪涌电流 8.3 ms单一正弦半波 Non-repetitive peak forward surge current 8.3 ms single half sine-wave	I_{FSM}	400							A
引线 and 管壳间绝缘强度 Dielectric strength Terminals to case	V_{dis}	2500							V
熔断系数 $t \leq 8.3$ ms Current squared time $t \leq 8.3$ ms	I^2t	530							A ² S
典型热阻 Typical thermal resistance (Note 1、2)	$R_{\theta JA}$	22							°C/W
	$R_{\theta JC}$	0.8							
工作结温 Operating junction temperature	T_J	150							°C
存储温度 Storage temperature range	T_{STG}	-55 --- +150							°C

备注 Note:

- 1) 安装在PCB板上, 从PN结到周围环境的热阻。
1) Thermal resistance from junction to ambient, PCB mounted.
- 2) 安装在PCB板上, 从PN结到管体的热阻。
2) Thermal resistance from junction to case, PCB mounted.

电特性 TA = 25°C 除非另有规定。

Electrical Characteristics Ratings at 25°C ambient temperature unless otherwise specified.

参数 Parameter	符号 Symbols	D35S B05	D35S B10	D35S B20	D35S B40	D35S B60	D35S B80	D35S B100	单位 Unit
最大正向电压 @IF=17.5A Maximum forward voltage	V_F	1.10							V
最大反向电流 @V _{DC} TA= 25°C Maximum reverse current	I_R	10							μA

特性曲线 Characteristic Curves

正向特性曲线 (典型值)

TYPICAL FORWARD CHARACTERISTIC

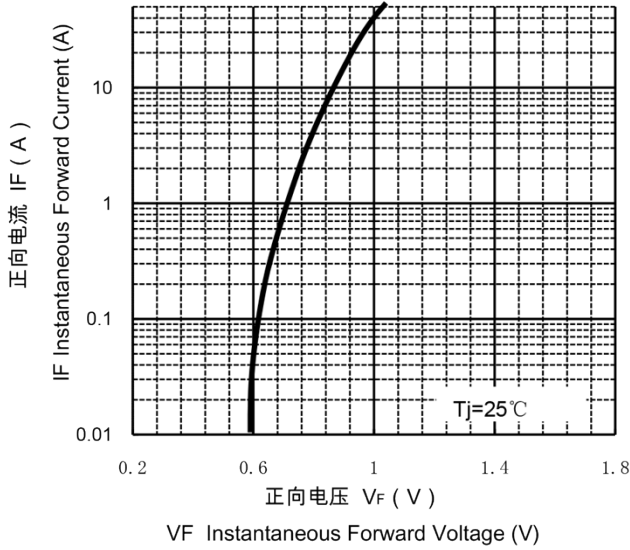

正向电流降额曲线

FORWARD CURRENT DERATING CURVE

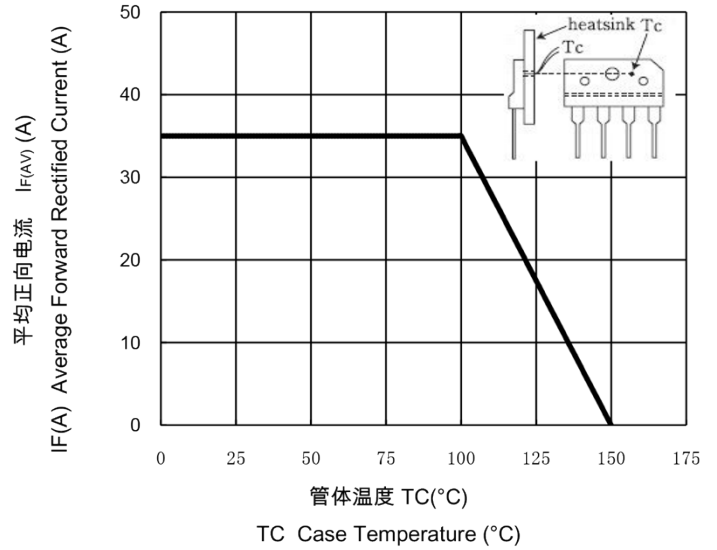

浪涌特性曲线 (最大值)

MAXIMUM NON REPETITIVE
PEAK FORWARD SURGE CURRENT

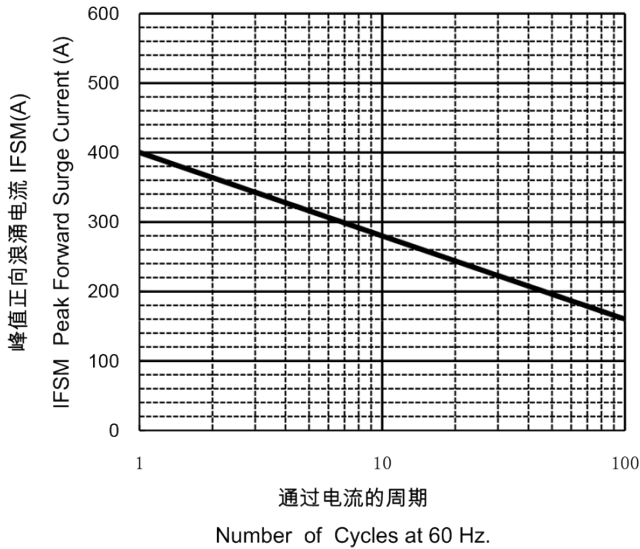

反向特性曲线

TYPICAL REVERSE CHARACTERISTICS

